

The 4193B Check Valve Strainer provides a dual function of protecting the orifice tip from clogging as well as preventing the nozzle from dripping after the line pressure is shut-off.

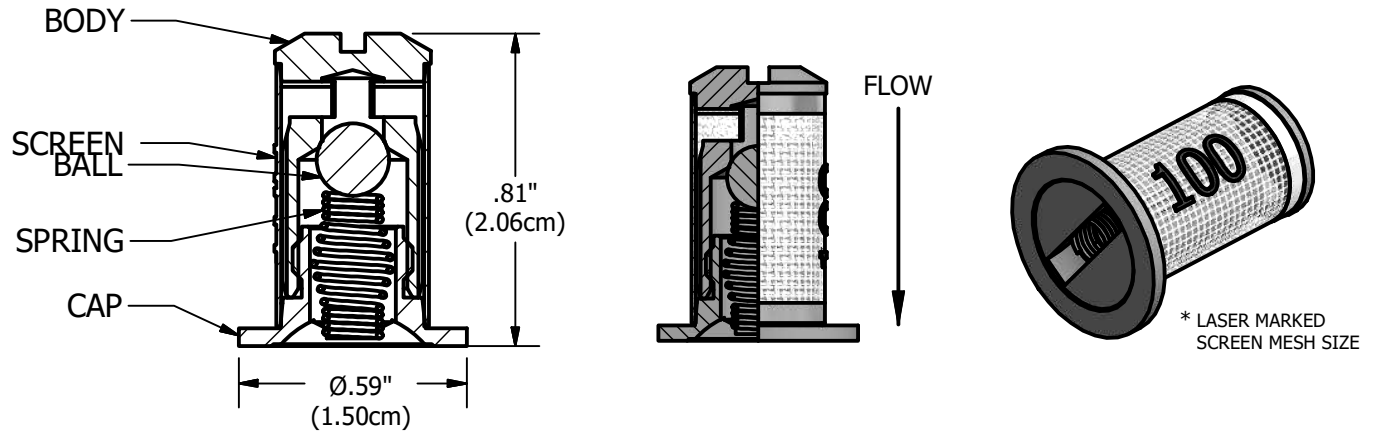

**HOW TO ORDER:**

CHECK VALVE NO.	MATERIAL		
	BODY AND CAP	BALL	SCREEN
4193B-_-*SS	BRASS	STAINLESS STEEL	STAINLESS STEEL
4193B-AL-_-*SS	ALUMINUM	STAINLESS STEEL	STAINLESS STEEL
4193B-SS-_-*SS	STAINLESS STEEL	STAINLESS STEEL	STAINLESS STEEL
4193B-PP-_-*SS	POLYPROPYLENE	FKM	STAINLESS STEEL
4193B-PP-_-SS-*SS	POLYPROPYLENE	STAINLESS STEEL	STAINLESS STEEL

\_ SPECIFY SPRING RATING - 5 OR 10 PSI.

\* SPECIFY SCREEN MESH SIZE - 24, 50, 80, 100 OR 200.

**EXAMPLES:**

4193B-5-50SS BRASS BODY, 5 PSI SPRING, 50 MESH, STAINLESS BALL  
 4193B-SS-10-80SS STAINLESS BODY, 10 PSI SPRING, 80 MESH, STAINLESS BALL  
 4193B-PP-5-100SS POLYPROPYLENE BODY, 5 PSI SPRING, 100 MESH, FKM BALL

**MESH COLOR (POLYPROPYLENE BODY ONLY):**

SCREEN MESH SIZE	24	50	80	100	200
COLOR					
COLOR NAME	WHITE	GENTIAN BLUE	ZINC YELLOW	TRAFFIC GREEN	LIGHT PINK

**PRESSURE DROP:**

FLOW RATE (GPM)	0.3	0.4	0.6	0.8	1.0	1.5
PRESSURE DROP (PSI)	5	6	8	10	12	20

THE 4193B CHECK VALVE STRAINERS CAN BE USED WITH MOST FLAT SPRAY, HOLLOW CONE SPRAY, FULL CONE SPRAY AND SOLID STREAM TIPS.  
 NOT COMPATIBLE WITH TTI, AI OR DG TIPS.

**DESCRIPTION:**

No. 4193B-\_-\_-SS  
 Check Valve Strainer



REVISION NO.	2	Data Sheet No.	
REFERENCE:	10/5/18	<b>DS4193B</b>	
SHEET:	1 OF 1	DWG SIZE:	A